

TF - FILLER BREATHER CAPS WITH INTERNAL THREAD

TFA - FILLER BREATHER CAPS WITH INTERNAL THREAD AND DIPSTICK

NYPO-24 - PUSH-FIT FILLER BREATHER



f = Air filter
G = Flat rubber seal

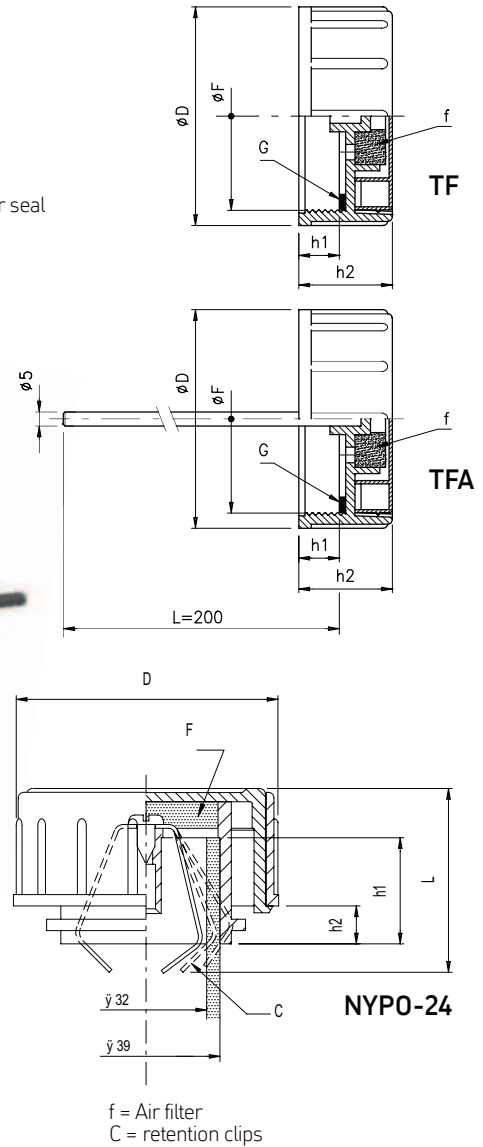

Model TF/TFA

-Female threaded filler breather caps, thread: M60x2, or 2" BSP.

-Produced from Polyamide 66, this cap offers high mechanical resistance at both low and higher temperatures (max 100° C), whilst shock resistant.

-The standard Filler Breather cap is produced in the color Red for oil and Yellow for Diesel fuel. On large orders the Breather can be provided in custom colors.

-Air filter element made from Polyurethane foam PPI 60.

-Flat, Oil resistant NBR 70 shore seal.

-Model TFA comes with plated, steel dipstick (diameter 5 mm), produced in a length of 200 mm.

-Airflow capacity at a pressure of 50 mbar (0,73 psi) = 35

liters/minute.

-In case of large orders, the dipstick can be cut to customers requirements. Further, the dipstick can be provided with "MIN-MAX" notches.

Model NYPO-24

-Filler breather with spring retention clips to suit 39mm OD and 32 mm ID steel boss.

-Red lid with "fill" graphic symbol.

-Air filter element made from Polyurethane foam PPI 60.

-Airflow capacity at a pressure of 50 mbar (0,73 psi) = 430 liters/minute.

Code	F	D	h1	h2
TF/2 TFA/2	G 2"	67,5	15	30
TF/60.2 TFA/60.2	M60x2	67,5	15	30

Code	D	L	h1	h2
NYPO-24	70	49	35	8

plugs, breathers and dipsticks