

## TCNB - PLASTIC PLUGS WITH INTERNAL HEX HEAD

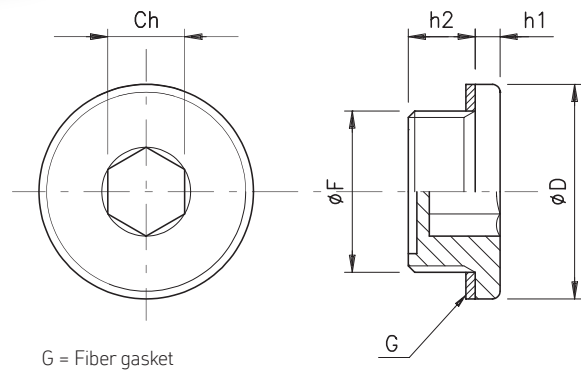

- Socket style low profile threaded plugs.
- Made from reinforced thermoplastic PA 66 material with 30% fiberglass providing an excellent mechanical resistance at both low and high temperatures.
- Max operating temperature **100°C** (continuous working), **120°** for short periods.
- Fiber gasket; alternative O-Ring NBR 70 Shore or flat NBR 70 Shore seal (adding to the code the suffix /G).

- For tightening torques (Nm = maximum allowable tightening torque) see the above table.
- Special execution in Polyamide reinforced with 50% fiberglass suggested to be used on industrial application where high resistance to deformation and to mechanical shocks are requested. Max operating temperature **120°C** (continuous working), **150°** for short periods.

Code	F	Ch	D	h1	h2	Nm	Nm 50% FV
TCNB/14	G 1/4"	6	18	3	8	3÷5	5÷7
TCNB/38	G 3/8"	8	22,5	3,5	10,5	6÷8	8÷10
TCNB/12	G 1/2"	10	28	4	10	8÷10	10÷12
TCNB/34	G 3/4"	12	35	4	10,5	10÷12	18÷20
TCNB/14.15	M 14x1,5	6	20	2,5	9	3÷5	5÷7
TCNB/16.15	M 16x1,5	8	22,5	3,5	10,5	6÷8	8÷10
TCNB/18.15	M 18x1,5	10	26	3	10	7÷9	10÷12
TCNB/20.15	M 20x1,5	10	28	3,5	10,5	7÷9	10÷12
TCNB/22.15	M 22x1,5	10	28	3,5	10,5	7÷9	10÷12
TCNB/26.15	M 26x1,5	12	35	3	11,5	10÷12	18÷20