

## 33 A - BREATHER PLUGS with vent valve

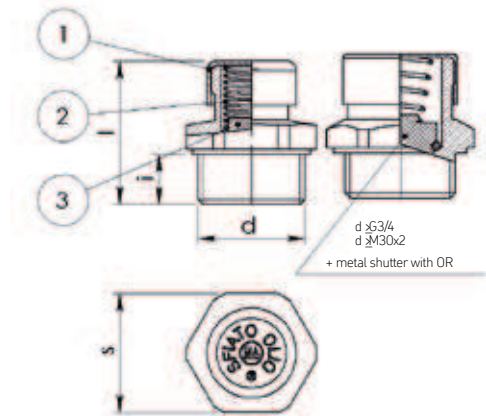

- (1) Protection cap: Steel white zinc plated
- (2) Spring: Stainless steel
- (3) Internal seal: NBR

-Threaded metal plugs made from brass, cap made in steel zinc plated, internal one-way vent valve.

-Fiber or aluminum sealing washer available.

-Maximum operating temperature **-10° + 90°C (+14 +194 F)**.

-The 33 A breather plug is designed to maintain a set internal pressure in gear boxes or other hydraulic units.

-The internal breather vent valve opens at either .15-.30 bar and exhausts excess pressure in the reservoir, and then closes once the preset pressure setting is reached.

-In off-highway applications the breather assists in containing oil leaks from the unit.

-The cap protects airborne contamination from entering the mechanical equipment.

-These plugs are designed for use in speed reducers, gearboxes, bearing housings and transmissions of all types.

-For sizes 1/4", 3/8", 1/2" and 3/4" possibility to supply conical threads.

Cod.	d	i (mm)	s (mm)	l (mm)	Weight (g)
33A-G.1/8	G1/8	7	14	21,5	14,5
33A-G.1/4	G1/4	9	17	29	30,5
33A-R.1/4	R1/4	10	17	29	32
33A-G.3/8	G3/8	9	20	28	38
33A-R.3/8	R3/8	10	19	27	32
33A-G.1/2	G1/2	10	24	29	61
33A-R.1/2	R1/2	11	22	30	56
33A-G.3/4	G3/4	12	32	35	98
33A-R.3/4	R3/4	14	32	37	88
33A-G.1	G1	13	40	43	194
33A-G.1 1/4	G1 1/4	15,5	50	53	510
33A-G.1 1/2	G1 1/2	15	55	53	600
33A-M10x1	M10x1	7	14	22	14,5
33A-M12x1,5	M12x1,5	9	17	29	30
33A-M14x1,5	M14x1,5	9	17	29	32
33A-M16x1,5	M16x1,5	9	22	28	44
33A-M18x1,5	M18x1,5	9	22	28	45,6
33A-M20x1,5	M20x1,5	10	24	32	71
33A-M22x1,5	M22x1,5	10	27	30	81
33A-M24x1,5	M24x1,5	11	30	33	120
33A-M24x2	M24x2	11	30	33	120
33A-M30x2	M30x2	12	36	35	150
33A-M33x2	M33x2	13,5	40	41	190
33A-M42x3	M42x3	15,5	50	50,5	510